

Residential Deck Information for Single- and Two-Family Dwellings ONLY

Type of Lumber _____ Detached _____ Attached _____
Address _____

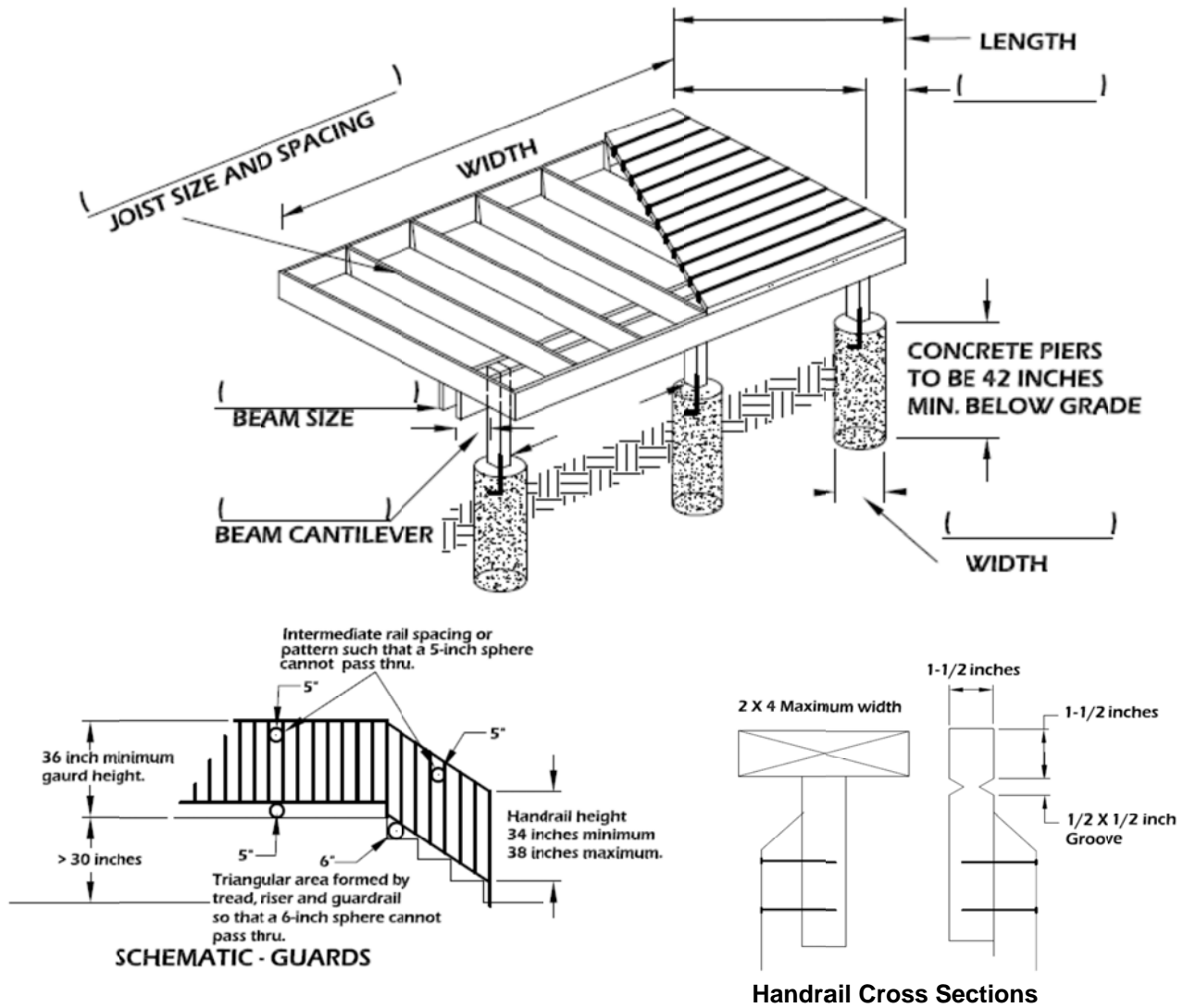

Location. Decks and stairs shall not be located closer than 3 feet to the property line. Stairs and decks located closer than 3 feet to the property line shall be of fire-resistive construction.

Frost Depth Footings. All decks attached to a dwelling unit shall be frost depth footings a minimum of 42 inches in depth below grade.

Stairs, Handrails, and Guards

Width. Stairways shall not be less than 36 inches in clear width at all points above the permitted handrail height and below the required headroom height. Handrails shall not project more than 4 1/2 inches on either side of the stairway. The minimum clear width of the stairway at and below the handrail height, including treads and landings, shall not be less than 31 1/2 inches where a handrail is installed on one side and 27 inches where handrails are provided on both sides.

Treads and Risers. The maximum riser height shall be 8 inches and the minimum tread depth shall be 10 inches. The riser height shall be measured vertically between leading edges of the adjacent treads. The tread depth shall be measured horizontally between the vertical planes of the foremost projection of adjacent treads and at a right angle to the tread's leading edge. The walking surface of treads and landings of a stairway shall be sloped no steeper than 1 unit vertical in 48 units horizontal (2 percent slope). The greatest riser height within any flight of stairs shall not exceed the smallest by more than 3/8 inch. The greatest tread depth within any flight of stairs shall not exceed the smallest by more than 3/8 inch.

Handrails. Handrails having minimum and maximum heights of 34 inches and 38 inches, respectively, measured vertically from the nosing of the treads shall be provided on at least one side of stairways. All required handrails shall extend the full length of the stairs with four or more risers from a point directly above the top riser of a flight to a point directly above the lowest riser of the flight. Handrails adjacent to a wall shall have a space of not less than 1.5 inches between the wall and the handrail.

Guards. Guards shall be located along open-sided walking surfaces, including stairs, ramps, and landings, that are located more than 30 inches measured vertically to the floor or *grade* below at any point within 36 inches horizontally to the edge of the open side. Insect screening shall not be considered as a guard.

Height. Required guards at open-sided walking surfaces, including stairs, porches, balconies, or landings, shall be not less than 36 inches high measured vertically above the adjacent walking surface, adjacent fixed seating, or the line connecting the leading edges of the treads.

Exceptions:

1. Guards on the open sides of stairs shall have a height not less than 34 inches measured vertically from a line connecting the leading edges of the treads.
2. Where the top of the guard also serves as a handrail on the open sides of stairs, the top of the guard shall not be less than 34 inches and not more than 38 inches measured vertically from a line connecting the leading edges of the treads.

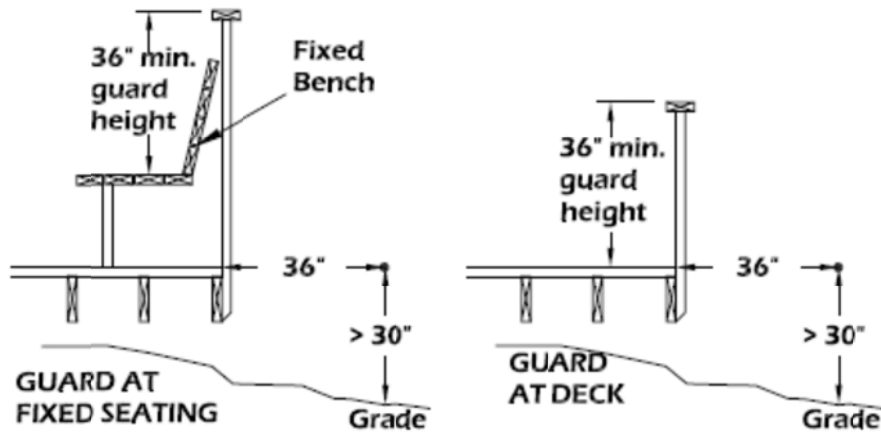

Opening limitations. Required guards shall not have openings from the walking surface to the required guard height which allow passage of a sphere 5 inches in diameter.

Exceptions: The triangular openings at the open side of a stair, formed by the riser, tread, and bottom rail of a guard, shall not allow passage of a sphere 6 inches in diameter.

Stairway illumination. Exterior stairways shall be provided with a means to illuminate the stairs by an artificial light source located in the immediate vicinity of the top landing of the stairway. The illumination of exterior stairways shall be controlled from the inside of the dwelling unit or be continuously illuminated or automatically controlled.

Decks. Where supported by attachment to an exterior wall, decks shall be positively anchored to the primary structure and designed for both vertical and lateral loads as applicable. Such attachment shall not be accomplished by the use of toenails or nails subject to withdrawal. Where positive connection to the primary building structure cannot be verified during inspection, decks shall be self-supporting. For decks with cantilevered framing members, connections to exterior walls or other framing members shall be designed and constructed to resist uplift resulting from the full live load specified in Table 3/R301.5 acting on the cantilevered portion of the deck.

Deck Ledger Connection to Band Joist. For decks supporting a total design load of 50 pounds per square foot [40 pounds per square foot live load plus 10 pounds per square foot dead load], the connection between a deck ledger of pressure-preservative-treated Southern Pine, incised pressure-preservative-treated Hem-Fir, or *approved* decay-resistant species, and a 2-inch nominal lumber band joist bearing on a sill plate or wall plate shall be constructed with 1/2-inch lag screws or bolts with washers in accordance with Table 9/R507.2. Lag screws, bolts, and washers shall be hot-dipped galvanized or stainless steel.

Table 9/R507.2
Fastener Spacing for a Treated Southern Pine Deck Ledger
and a 2-inch Nominal Solid-Sawn Spruce-Pine-Fir Band Joist^{c, f, g}
(Deck live load = 40 psf, deck dead load = 10 psf)

JOIST SPAN	6' and less	6' 1" to 8'	8' 1" to 10'	10' 1" to 12'	12' 1" to 14'	14' 1" to 16'	16' 1" to 18'
Connection details				On-center spacing of fasteners ^{d,e}			
1/2-inch diameter lag screw with 15/32-inch maximum sheathing ^a	30	23	18	15	13	11	10
1/2-inch diameter bolt with 15/32-inch maximum sheathing	36	36	34	29	24	21	19
1/2-inch diameter bolt with 15/32-inch maximum sheathing and 1/2-inch stacked washers ^{b,h}	36	36	29	24	21	18	16

- a. The tip of the lag screw shall fully extend beyond the inside face of the band joist.
- b. The maximum gap between the face of the ledger board and face of the wall sheathing shall be 1/2 inch.
- c. Ledgers shall be flashed to prevent water from contacting the house band joist.
- d. Lag screws and bolts shall be staggered in accordance with the drawing on the next page.
- e. Deck ledger shall be minimum 2 x 8 pressure-preservative-treated No. 2 grade lumber, or other approved materials as established by standard engineering practice.
- f. When solid-sawn pressure-preservative-treated deck ledgers are attached to a minimum 1-inch-thick engineered wood product (structural composite lumber, laminated veneer lumber, or wood structural panel band joist), the ledger attachment shall be designed in accordance with accepted engineering practice.
- g. A minimum 1 x 9 1/2 Douglas Fir laminated veneer lumber rim board shall be permitted in lieu of the 2-inch nominal band joist.
- h. Wood structural panel sheathing, gypsum board sheathing, or foam sheathing not exceeding 1 inch in thickness shall be permitted. The maximum distance between the face of the ledger board and the face of the band joist shall be 1 inch.

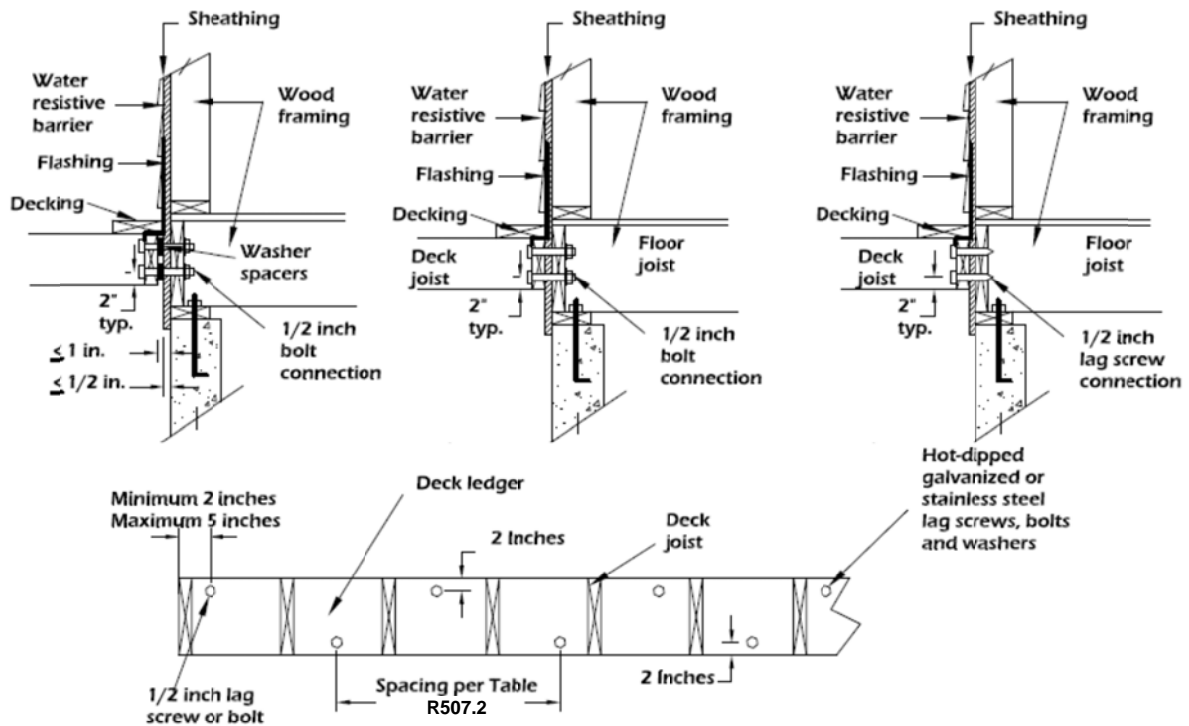

DECK LEDGER CONNECTION

Placement of Lag Screws or Bolts in Deck Ledgers. The lag screws or bolts shall be placed 2 inches in from the bottom or top of the deck ledgers and between 2 and 5 inches in from the ends. The lag screws or bolts shall be staggered from the top to the bottom along the horizontal run of the deck ledger.

Alternate Deck Ledger Connections. Deck ledger connections not conforming to Table 9/R507.2 shall be designed in accordance with accepted engineering practice. Girders supporting deck joists shall not be supported on deck ledgers or band joists. Deck ledgers shall not be supported on stone or masonry veneer design capacity of not less than 1,500 pounds.

Flashing. Flashing shall always be installed at the deck ledger board connection and the structure as shown above.

Exterior Wood/Plastic Composite Deck Boards. Wood/plastic composite deck boards shall be installed in accordance with the manufacturer's instructions.

Allowable Deck Joist Spans. Spans for deck joists shall be in accordance with the Table 11/Residential Deck Joist Spans. For other grades and species and for other loading conditions, refer to Table R502.3.1(2) IRC and/or to the AF&PA Span Tables for Joists and Rafters.

**Table 11/Residential Deck Joist Spans
Cedar and Redwood
Live Load = 40 psf Dead Load = 5 psf**

• Building Services • City of Sioux Falls • 2012 IRC

Size	Spacing	Span		
		Western Cedars #2 and Better	Span Redwood Construction and Better	Green Treated SP #2 and Better
2x6	12" OC	9'2"	8'10"	10'8"
	16" OC	8'4"	8'0"	9'9"
	24" OC	7'3"	7'0"	8'6"
2x8	12" OC	12'1"	11'8"	14'1"
	16" OC	11'0"	10'7"	12'10"
	24" OC	9'7"	9'3"	11'2"
2x10	12" OC	15'5"	14'10"	18'0"
	16" OC	14'0"	13'6"	16'4"
	24" OC	12'3"	11'9"	13'10"
2x12	12" OC	18'9"	18'1"	21'11"
	16" OC	17'0"	16'5"	19'10"
	24" OC	14'10"	14'4"	16'2"

Design Criteria: Lengths are based on an extreme fiber stress in bending of 700 psf for No. 2 or better western cedar and 825 psi for construction grade or better redwood. Moduli of elasticity is based on 1,000,000 psi for No. 2 or better western cedar and 900,000 psi for construction grade or better redwood. Spans for green-treated lumber are based on a No. 2 grade or better southern pine with a moduli of elasticity of 1,600,000 psi and a fiber stress in bending of: 1,250 psi for 2x6s; 1,200 psi for 2x8s; 1,050 psi for 2x10s; and 975 psi for 2x12s. Deflection is limited to the span in inches divided by 360 for the live load only. Spans are based on a live load of 40 psf and a dead load of 5 psf. A repetitive member factor of 15 percent has been included. Note: Said spans are not applicable to an exterior balcony, which is defined as a floor system projecting from a structure and supported by that structure—with no additional supports—which must be designed for all applicable dead loads and a live load of 60 psf.